

THIRTY-THIRD AVENUE

26'

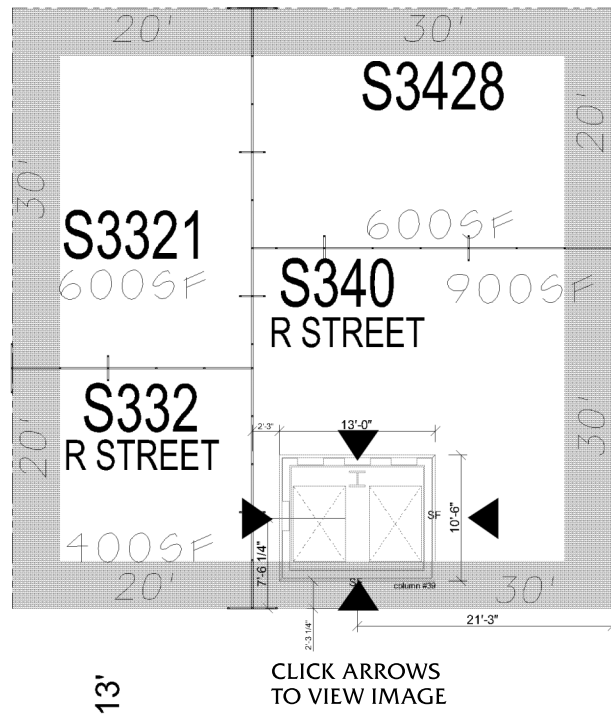

13'

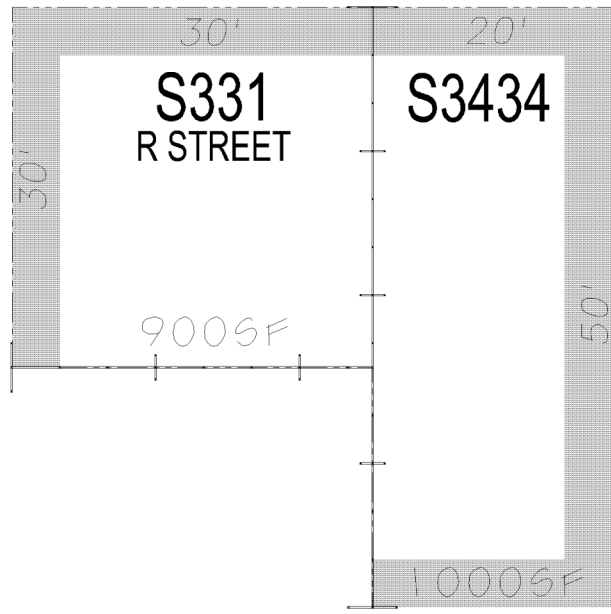

26'

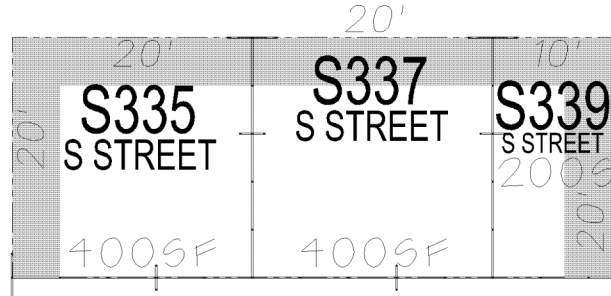

THIRTY-FOURTH AVENUE

20'

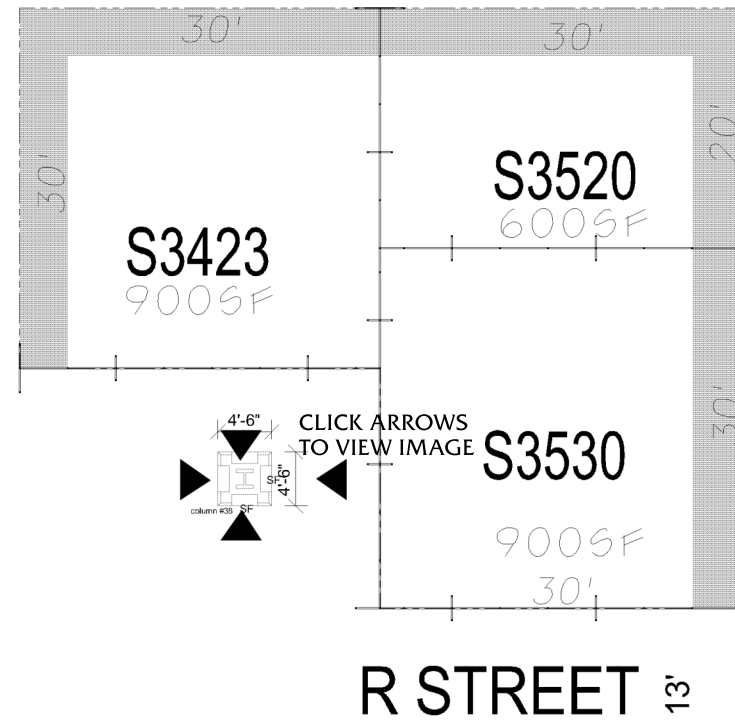

R STREET

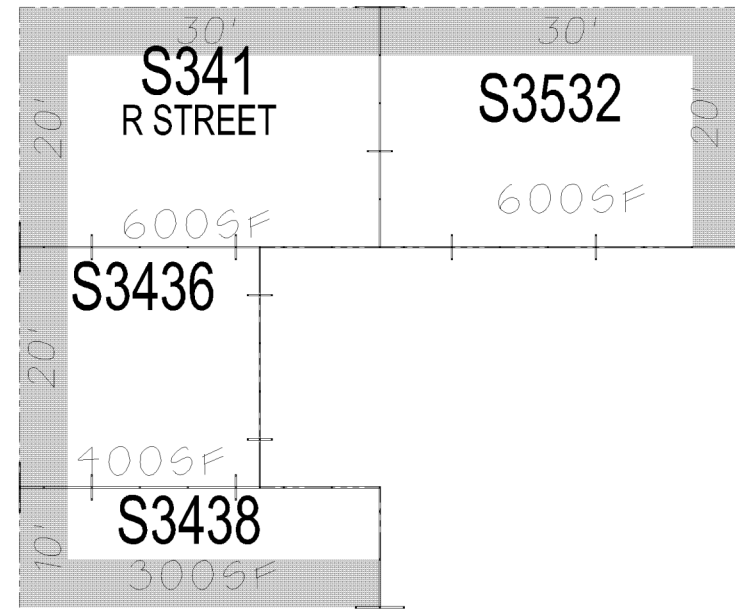

S STREET

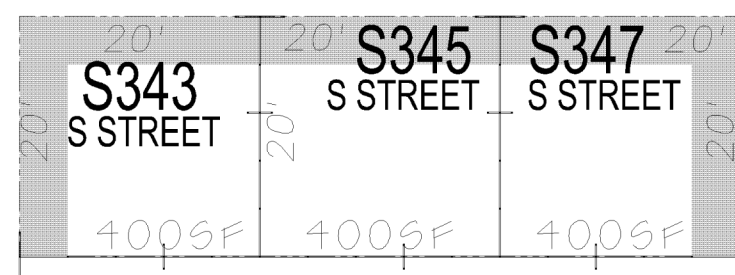

THIRTY-FIFTH AVENUE

10'

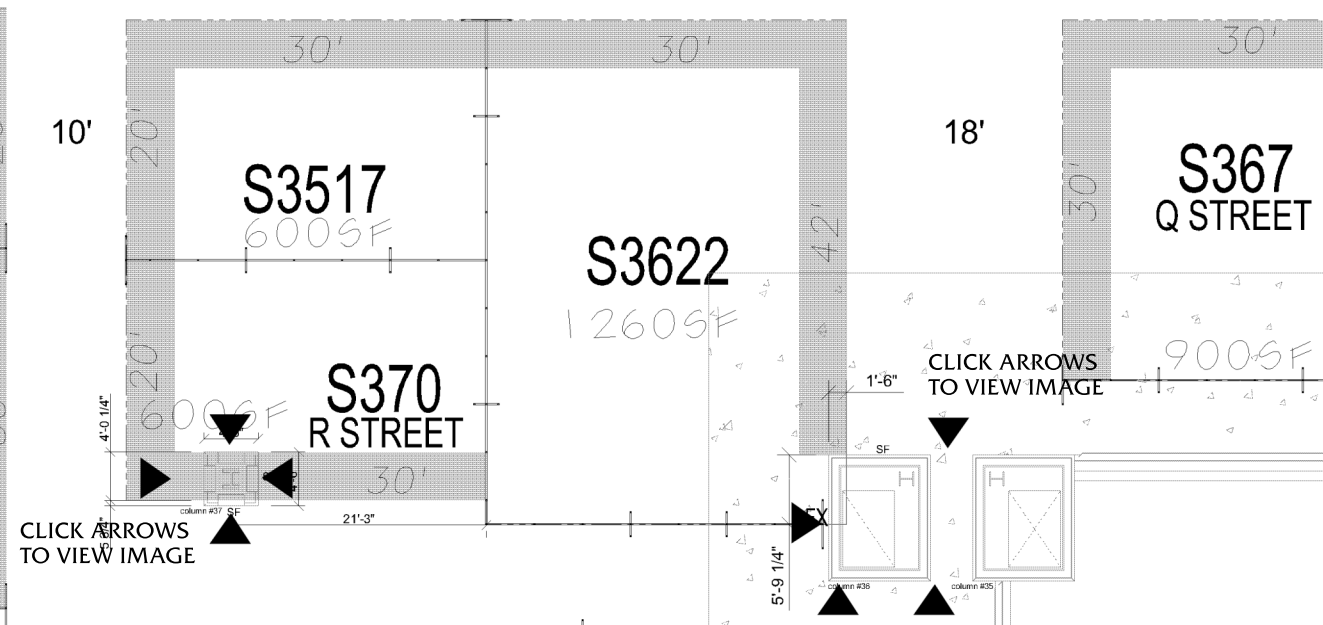

concessi

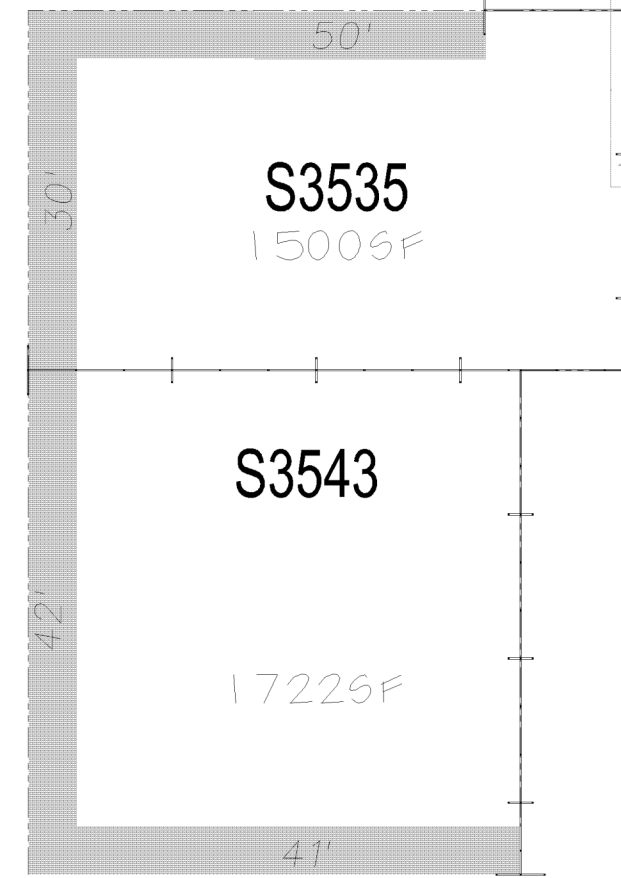

AREA DRAWING

63

\* These are working plans and are subject to frequent changes.

\* To see a photo of each side of any column and it's utilities click on the corresponding arrows.

ICSC RECon 2008 LEASING MALL

- For all Area Drawings, Design Criteria, Rules & Regulations and Floor Plans, plus an e-mail link for additional questions see <http://www.icsc.org>. All drawing files are in PDF format.
- Due to structural requirements wing walls cannot be removed without prior approval from GES and DDG. Wing walls at face of booth are 2' wide, and 1' at interior of booth (typically 12" o.c.).
- Access to all fire hose cabinets (FHC) and fire extinguishers (FX) must be maintained at all times.

DATE: 05/12/08  
SCALE: 1/16"=1'-0"